



**CLEMCO**  
The Performance  
System

## TECHNICAL DATA SHEET

*Note: For safe, efficient blasting, read and follow the owner's manual and seek training for everyone who will use this equipment.*

### Purpose

OSHA regulations require remote controls on all abrasive blast machines.

Pneumatic remote control systems operate efficiently with up to 100 feet of twinline control hose. Electric remote control systems operate efficiently at distances up to 500 feet. For distances greater than 300 feet, special remote control cable is required.

### Requirements for Operation

These items are required but are not included with the handle:

- Twinline remote control hose (for pneumatic handles)
- Electric cord (for electric handles)
- Blast machine fitted with Clemco remote control valves
- Power source (for electric handles)

### Description of Operation

Pressing the remote control handle activates the system and starts blasting; releasing the handle stops blasting. When the handle is released, a spring-loaded lever mechanism keeps the handle from accidentally activating the system.

The pneumatic handle utilizes twinline hose (both sides of the twinline are 3/16" ID). Air travels out one side of the twinline hose and escapes from an orifice in the handle. When the handle is pressed, a rubber button blocks the orifice, diverting the air back along the other side of the twinline hose. The returning air activates the remote control valves to begin blasting.

Electric remote controls use an electric cord and micro-switch in place of the twinline hose and orifice used in pneumatic handles. Electric handles operate on 12 volts.

## Description

Control handle for remote activation and deactivation of an abrasive blast machine. Fail-to-safe system stops blasting if operator drops or loses control of the handle. For use with Clemco remote control systems only.

# RLX Pneumatic & Electric Remote Control Handles



RLX Pneumatic Handle

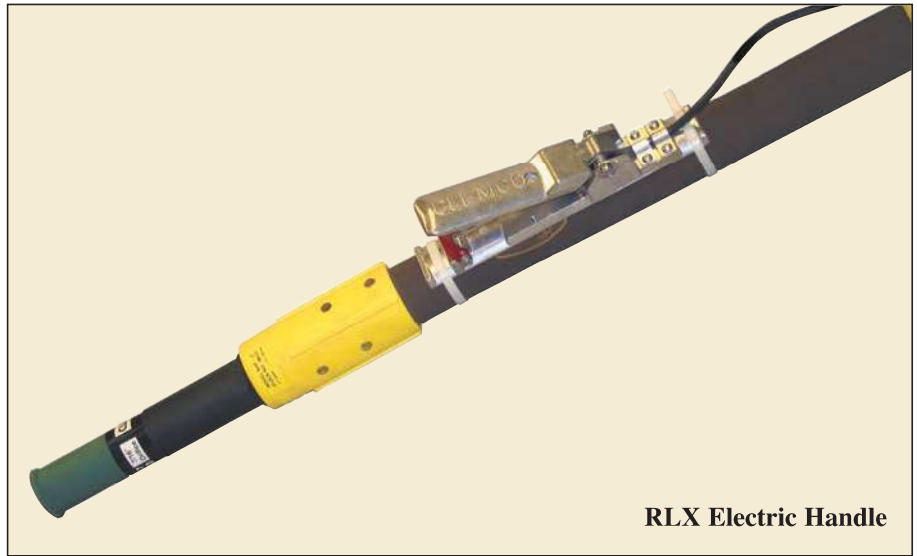

RLX Electric Handle

NOTE: Remote control systems operate on 12-volt DC or 120-volt AC, but for safety, the power to the handle is always reduced to 12 volts.

All Clemco remote control valves operate pneumatically. The electric signals from the remote control handle operate solenoids that, in turn, operate the pneumatic remote control system.

### WARNING!

**Never modify or substitute remote control parts. Parts from other manufacturers are NOT compatible with Clemco remote controls.**

### Advantages - Pneumatic

- Meets OSHA requirement for remote control system
- Twinline hose cannot be connected incorrectly
- Simple design is easy to service

### Advantages - Electric

- Meets OSHA requirement for remote control system
- Fast response at distances up to 500 feet
- Low-profile, threaded connectors secure neatly to hose

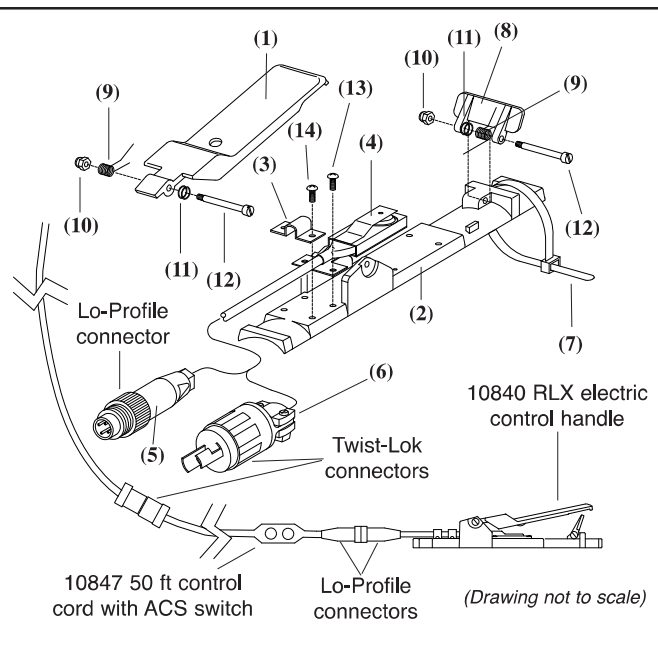
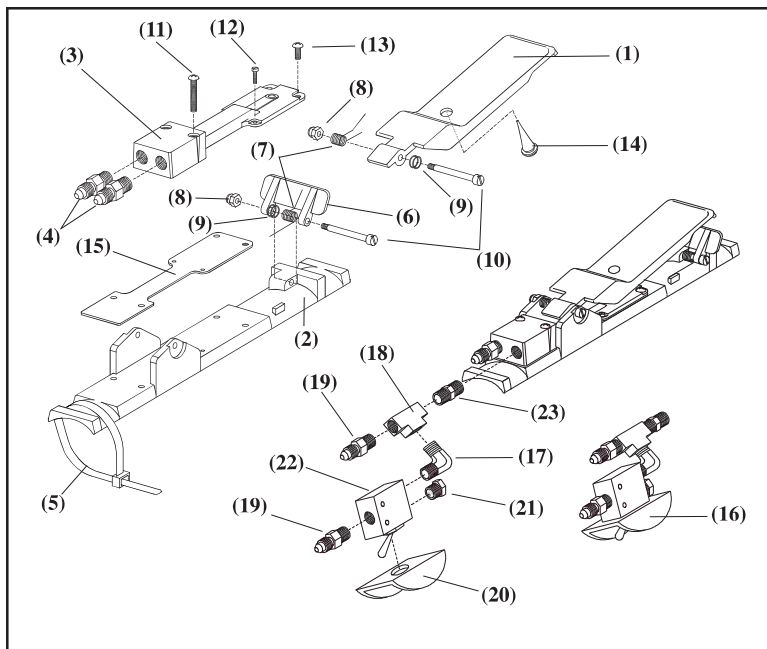

## RLX Pneumatic Control Handle Assembly

Item	Description	Stock No.
(-)	RLX Pneumatic control handle, complete	10565
(-)	RLX Pneumatic control handle with ACS	07625
(-)	Service Kit, RLX pneumatic control handle (K)	22859
1.	Handle	10573
2.	Body	10568
3.	Pneumatic adaptor	10562
4.	Adaptor 1/8" NPS, 2 reqd.	01940
5.	Tie, nylon wire, 2 reqd.	02195
6.	Lever lock (K)	10564
7.	Spring, lever, 2 reqd. (K)	05823
8.	Nut, 8-32 lock, s/s, 2 reqd. (K)	05815
9.	Spacer washer, s/s, 4 reqd. (K)	05434
10.	Screw, 3/16" x 1-1/4" shoulder, 2 reqd. (K)	05817
11.	Screw, 8-32 x 1" round head, 2 reqd. (K)	05819
12.	Screw, 4-40 x 3/8" fillister head, 2 reqd. (K)	05818
13.	Screw 8-32 x 3/8" s/s, round head, 2 reqd. (K)	05814
14.	Rubber bumper (K)	05821
15.	Gasket, pneumatic adaptor (K)	10563
<i>Parts included in the Service Kit are identified by (K).</i>		
16.	Switch assembly, ACS pneumatic	07654
17.	Elbow, 1/8" NPT male	03085
18.	Tee, 1/8" NPT brass	02171
19.	Adaptor, 1/8" NPT	01940
20.	Guard, ACS pneumatic switch	07655
21.	Breather muffler, 1/8" NPT	07657
22.	Switch only, ACS	07658
23.	Connector, 1/8" NPT, brass	01962

### Dimensions

Item	Stock No.	Weight
RLX Electric w/lo-profile connector	10840	1.2 lb
RLX Electric w/twist-lock connector	05801	1.2 lb
RLX Pneumatic handle	10565	1.0 lb
RLX Pneumatic handle with ACS	07625	1.1 lb

### Color

Aluminum

## RLX Electric Control Handle Assembly

Item	Description	Stock No.
(-)	RLX Electric handle w/lo-profile connector.	10840
(-)	RLX Electric handle w/twist-lock connector	05801
(-)	Cord, 50 ft, with ACS switch	10847
<i>Note: order 10840 and 10847 for electric RLX with ACS switch</i>		
1.	Handle	10573
2.	Body	10568
3.	Clamp, switch cord	05810
4.	Switch, electric with cord	24842
5.	Connector, lo-profile, male (for 10840 only)	10828
6.	Connector, twist-lock, male (for 05801 only)	02899
7.	Tie, nylon wire, 2 reqd.	02195
8.	Lever lock	10564
9.	Spring, lever, 2 reqd.	05823
10.	Nut, 8-32 lock, s/s, 2 reqd.	05815
11.	Spacer washer s/s, 4 reqd.	05434
12.	Screw, 3/16" x 1-1/4" shoulder, 2 reqd.	05817
13.	Screw, 4-40 x 3/8" fillister head, 2 reqd.	05818
14.	Screw, 8-32 x 3/8" s/s rnd. hd., 4 reqd.	05814

## Related Clemco Literature

Description	Stock No.
RLX-Pneumatic & RLX-Electric Owner's Manual	10574

## Packaging

Packed with owner's manual in 10" x 12" poly bag

Authorized Distributor:

ISO 9001 certified. Clemco is committed to continuous product improvement. Specifications are subject to change without notice.

© 2016 Clemco Industries Corp. • One Cable Car Drive • Washington, MO 63090 • Phone (636) 239-4300 • Fax (800) 726-7559

Stock No. 21957

www.clemcoindustries.com

0698 Rev. D 06/16